

Connection Diagram for Fail-Secure Lock

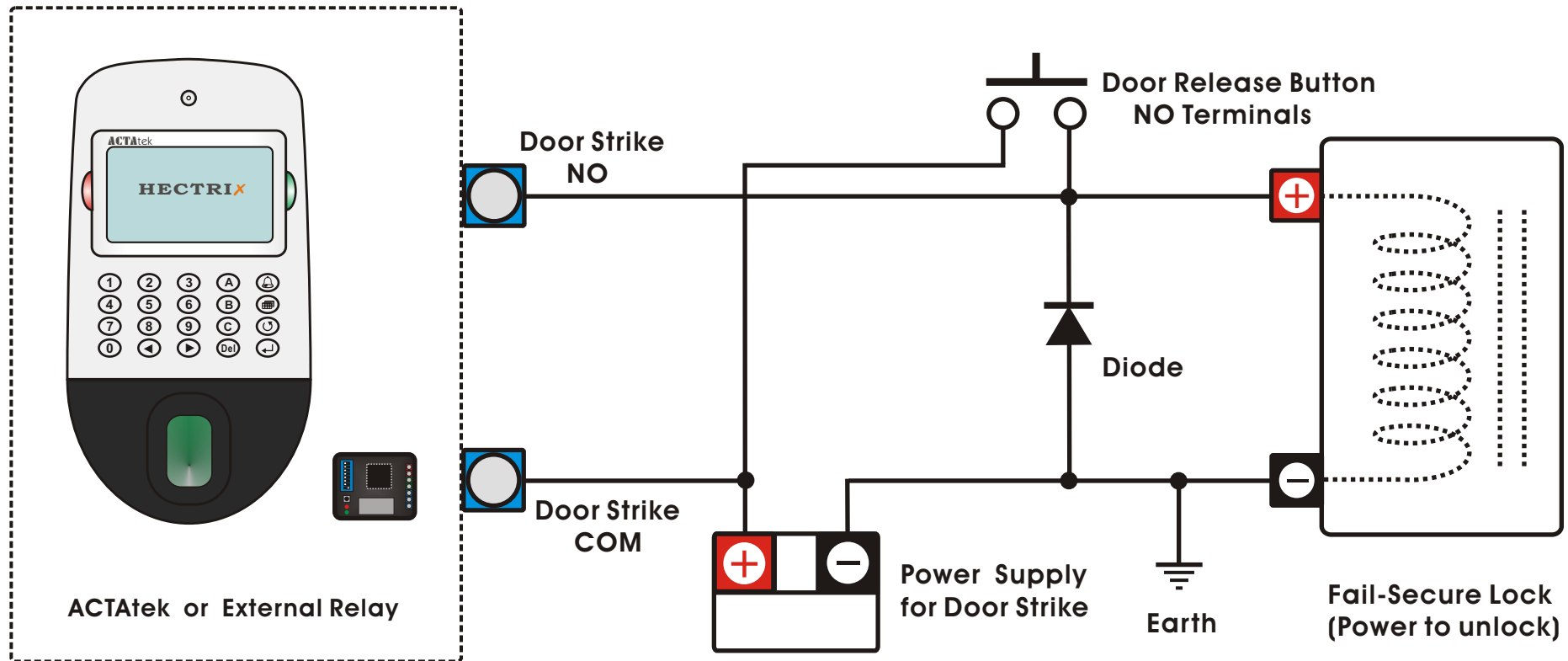

Description:

If the ACTAtek is used as an Access Control System, there are some instructions must to be followed:

- 1, ACTAtek supports door strike that rating at 12VDC/1A. If the operate current is above the limit, you should select External Relay. The door strike control wires must be connected to External Relay instead of wiring with ACTAtek direct.
- 2, Use separate power supply for ACTAtek; External Card Reader and External Relay, DO NOT share the power supply with Door Strike.
- 3, An additional Diode is required to avoid Back EMF from the Door Strike, which could damage the ACTAtek.
- 4, To operate a non-polar Door Strike, you should assign the Positive & Negative terminal for the Strike accorded with the polarity of Diode: The terminal that connects to Cathode End of Diode is Positive, the other one is Negative.
- 5, Diode Selection: a) Use P/N:1N4004, if the Door Strike rates at 12VDC/1A
b) Use P/N:6A1, if the Door Strike operating current is within 1 - 6A.

* Failing to comply the above installation instruction might cause severe damage to ACTAtek.

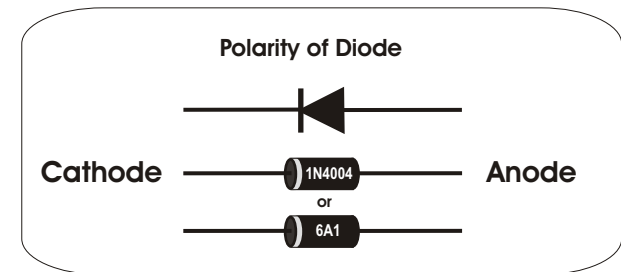

Title: Fail-Secure Lock Connection	
Author: Hectrix Ltd.	www.hectrix.com
Date: Feb. 25 2006	Sheet: 1 of 1
Revision: 1.05	